

# Maintenance & Operating Instructions

## For Dixon Bayco FT100 SERIES SENSORS FT101 SERIES SENSORS

### For Sales and Service Contact

Europe:  
Dixon Group Europe Ltd.  
Preston, England  
Phone: +44 (0) 1772 323529  
Fax: +44 (0) 1772 314664  
Email: [enquiries@dixoneurope.co.uk](mailto:enquiries@dixoneurope.co.uk)

Mexico:  
Dixva, S. de R.L. de C.V.  
Monterrey, N.L.  
Phone: 01-800-00-DIXON (34966)  
Fax: 01-81-8354-8197  
E-mail: [contactenos@dixonvalve.com.mx](mailto:contactenos@dixonvalve.com.mx)

Canada:  
Dixon Group Canada Limited  
Innisfil (Barrie), Ontario  
Phone: 705-436-1125  
Fax: 705-436-6251  
Toll Free: 877-963-4966  
E-mail: [isales@dixongroupcanada.com](mailto:isales@dixongroupcanada.com)

Asia Pacific:  
Dixon (Asia Pacific) Pty Ltd Wingfield, South  
Australia  
Phone: +61 8 8202 6000  
Fax: +61 8 8202 6099  
E-mail: [enquiries@dixonvalve.com.au](mailto:enquiries@dixonvalve.com.au)

USA:  
Dixon Bayco USA  
Chestertown, Maryland  
Phone: 410-778-2000  
Fax: 410-778-4702  
Toll Free: 800-355-1991  
E-mail: [dixonbayco@dixonvalve.com](mailto:dixonbayco@dixonvalve.com)



*The Right Connection®*

[dixonvalve.com](http://dixonvalve.com)

## INSTALLATION INSTRUCTIONS:

FloTech overfill probe housings can be mounted in a 2" NPT (2" BSPT for European style) female pipe coupling or through a 2 3/8" hole. When mounting in a 2 3/8" hole the gasket and lock nut provided are used to retain the probe holder in the tank shell or manhole. After the sensor is mounted remove the cap.

Loosen the probe clamp screw and adjust the probe to the correct level point. This is typically 60 gallons (227 liters) above the sensor prism OR 3% of compartment volume whichever is greater. It is not recommended cutting the standard 7" sensor to a shorter length. This will cause insufficient time to stop the flow of product within the load racks reaction time. Longer 12" or 18" sensors may be cut to length with a tubing cutter.

**IMPORTANT: The actual sensing point adjustment should be determined by the total response time required to prevent a tank overfill condition. The FloTech sensor reaction time is 35ms. Wet testing the sensor should switch instantaneous. The loading rack will also have a reaction time. Once the probe is adjusted to the proper height, tighten the clamp screw.**

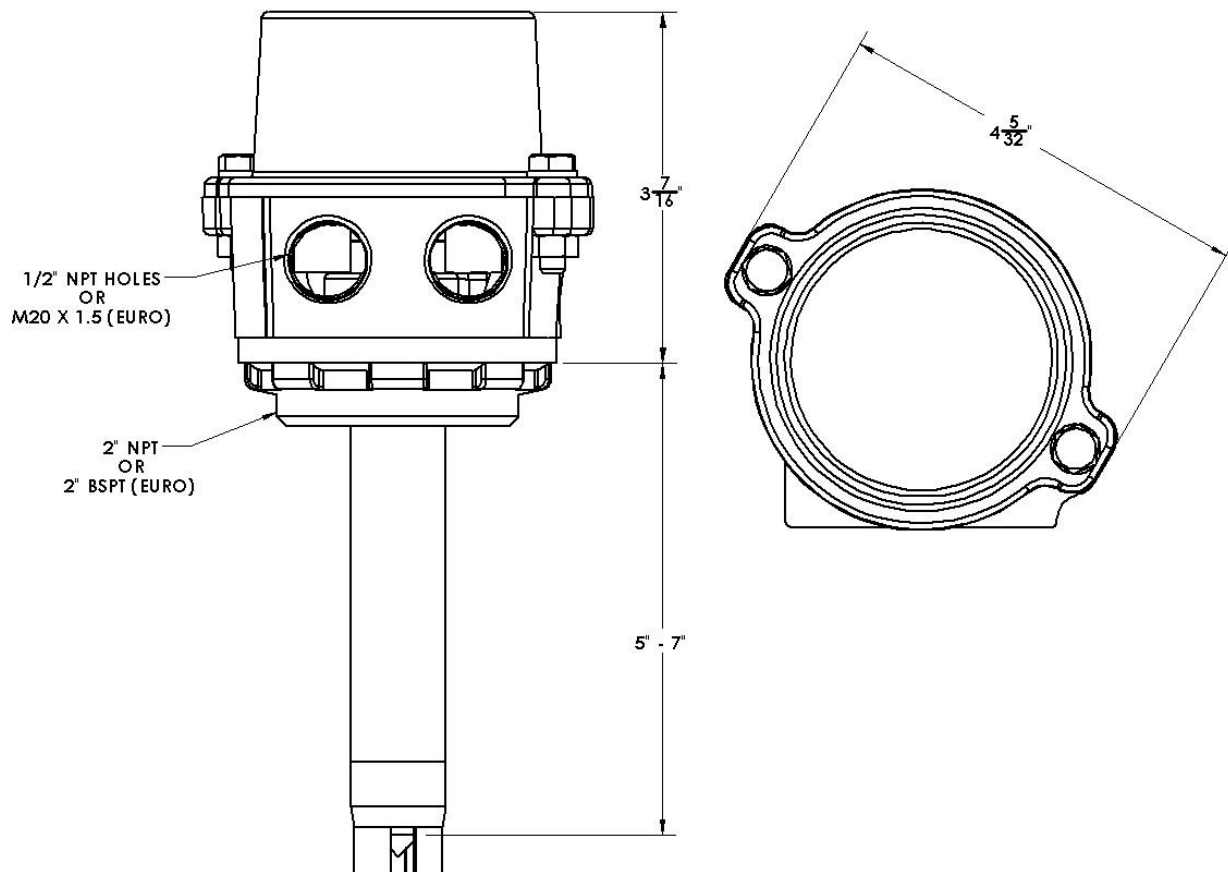

**WIRING INSTRUCTIONS:**

It is highly recommended to use FloTech FT400 jacketed 5-conductor cable when wiring a new system. FloTech cable is designed to be oil, UV, and abrasion resistant. We incorporate a noble tin plated stranded copper wire which resist corrosion. These features will provide years of reliable service. Do not use aftermarket cable if bare copper wire (reddish tint) is visible when the wire insulation is stripped.

After all sensors are mounted in each compartment, align the conduit openings so they face the roll over rail. Thread in cable glands and pull a length of cable through the conduit openings between each sensor. Cut to length leaving approximately 8 inches extra length exiting the top of each probe holder.

**FOR HOUSINGS USING NPT SIDE OPENINGS:**

All sensor wires must enter or leave through one of the ½ NPT openings. Use FloTech FT402 ½ NPT cable glands to ensure a water tight seal. Unused conduit openings must have a ½ NPT pipe plug installed. Use pipe dope on all ½ NPT threads to ensure a water tight seal.

**FOR EUROPEAN HOUSINGS USING METRIC M20 X 1.5 SIDE OPENINGS:**

All socket cables must enter or leave through one of the M20 X 1.5 threaded openings. Use FloTech FT402E M20 X 1.5 cable glands with thread sealant to ensure a water tight seal. Unused conduit openings must have a M20 X 1.5 plug with o-ring installed.

Wire the sensor according to the diagram below. Double check your wiring connection when complete. NOTE: It is highly recommended to use a small amount of Silicone RTV sealant in each crimp connection. Fill the FloTech butt end crimps with Silicone RTV sealant prior to inserting the wires then crimp. This will provide a watertight and vibration resistant connection that will last for years. **Do not use twist on connections “wire nuts”!**

When wiring is complete, replace each sensor cap and o-ring. CAUTION: Do not pinch a sensor wire when installing the cap.

Note: Trailer wiring for the US is different that trailer wiring in Canada. Both schematics are provided.

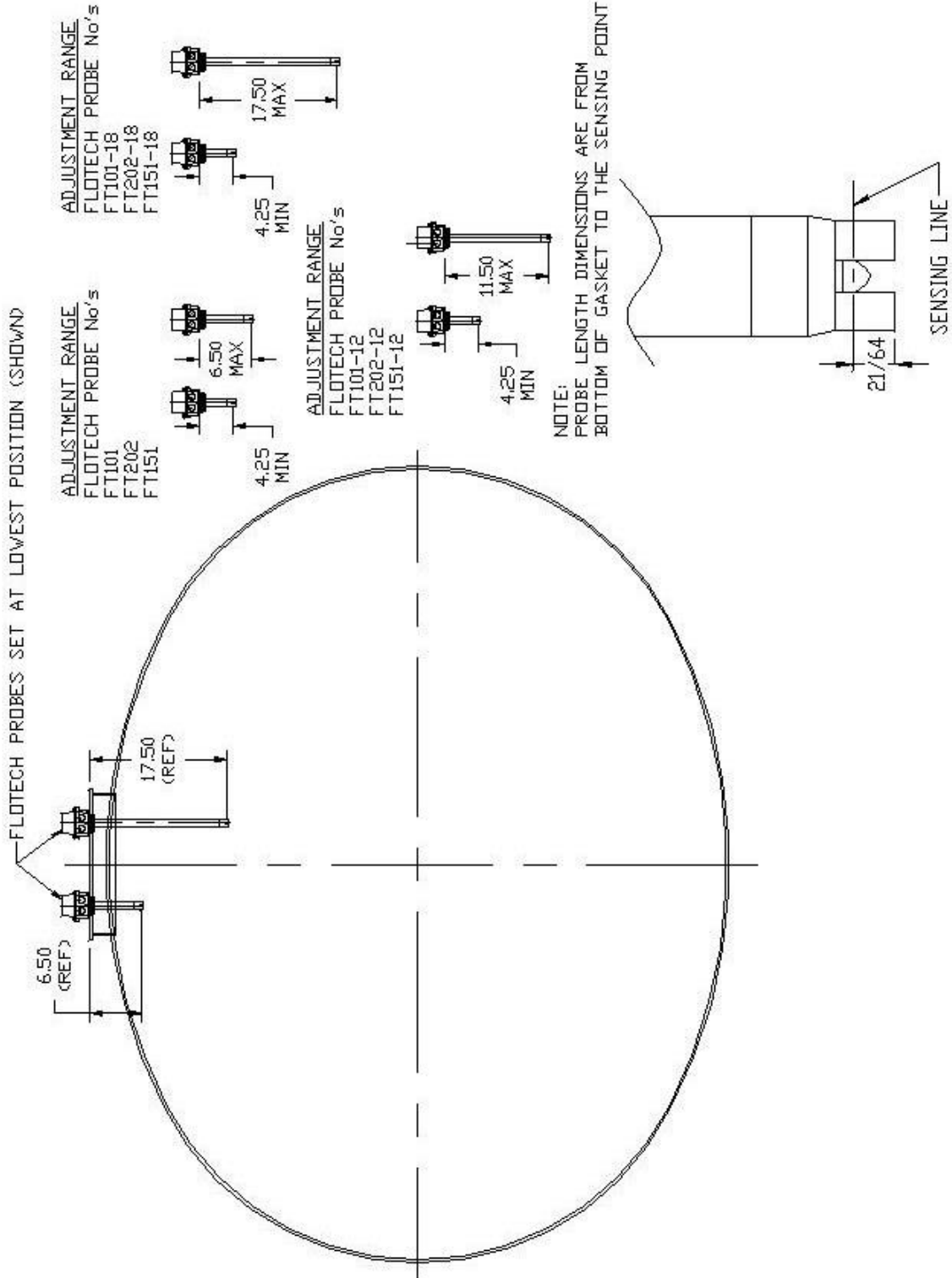

## US 4 COMPARTMENT SYSTEM

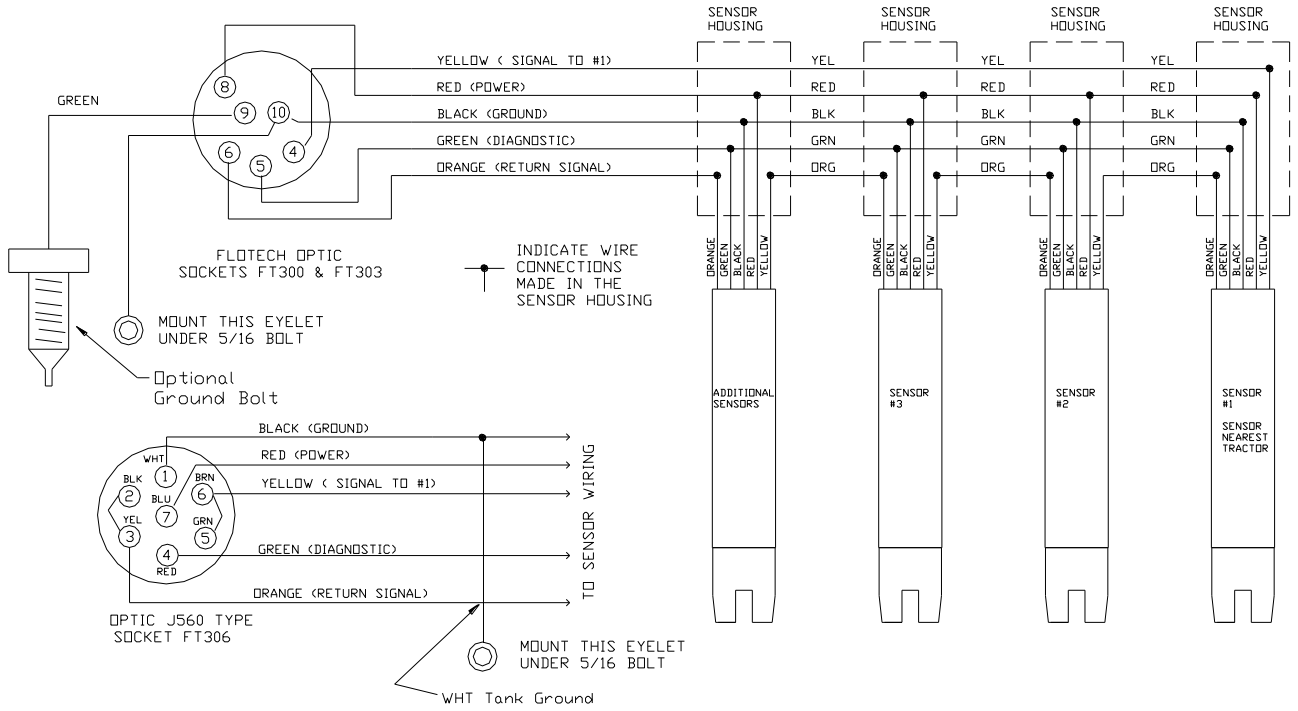

## CANADA 4 COMPARTMENT SYSTEM

